

# COMPACT LIFT TRANSPORTER

# Ergo Tranz®

ERGO TRONIX



## Options

- Customized load-handling End-Effectors.
- 2", 3", 4" or 5" Front Casters.

## Description

An innovative compact, battery-powered lift/transporter that allows anyone to practically and efficiently transport and lift when the material or object is too heavy or awkward for a person to lift and carry manually.

## Application

Unlimited applications in any industry. Advantageous in any warehouse, shopfloor or work area. Ideal in narrow and confined spaces. Ergo-Tranz replaces hand trolleys, stackers, winches with a simple and practical solution for every task.

## Ergonomic Benefit

- Eliminate employee strain, fatigue and injury.
- Create a safer and more productive work environment.

## Standard Features

- Light-weight, solid aluminum construction.
- Easily maneuverable in confined spaces and narrow aisles.
- Precision lift screw mechanism for lift position accuracy.
- Smooth, precise and accurate load positioning.
- Lift brake provides accurate positioning and safe holding with no creep.
- Customized, up to 3-axis, powered or non-powered end-effector attachments available.
- Hand pendant controls all lift and powered End-Effector functions.
- Available in 250 lbs., and 650 lbs. load capacities.
- Smart features like variable lift speed between 0 - 6"/sec. for precise positioning.
- Overload protection for operator safety and equipment protection.
- Sleep mode with touch button wake up to extend battery life.
- Heavy duty 24 Volt Li-Ion batteries (15 amp-hours) for many hours of operation between charges.
- Built-in high frequency solid-state universal charger (90-240VAC) with automatic charge cut-off and trickle float that can be left connected indefinitely without harming batteries.
- Lift-inhibit prevents operation during battery charging.
- Three-position foot-operated rear brake control system with parking brake, normal swivel or directional steering of rear casters.
- Solid state battery state-of-charge indicator.



## Solutions

CONVEY AND TRANSFER • LIFT • LIFT AND TRANSPORT • POSITION

# TECHNICAL INFORMATION

## Sample of End Effectors

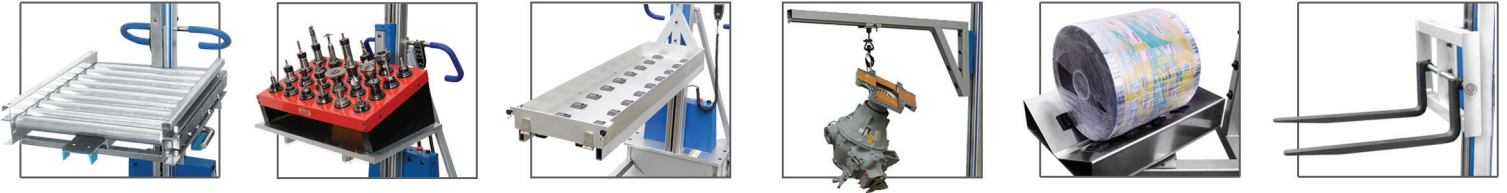

Model	Maximum Load Capacity at 12 L.C.	Standard Front Casters	Leg Height w/ Casters	Leg Width	Outer Leg Base Width	Stroke	Lifting Speed (variable)	Battery Pack Capacity Li-Ion	Weight with Batteries
ET-250	250 Lbs.	2"	3.5"	1¾"	24"	Floor to 57"	0 - 6" / Sec	24V DC, 15 Ah	180 Lbs.
ET-650	650 Lbs.	4"	6"	1¾"	24"	Floor to 57"	0 - 2" / Sec	24V DC, 15 Ah	210 Lbs.

ET-250 & ET-650

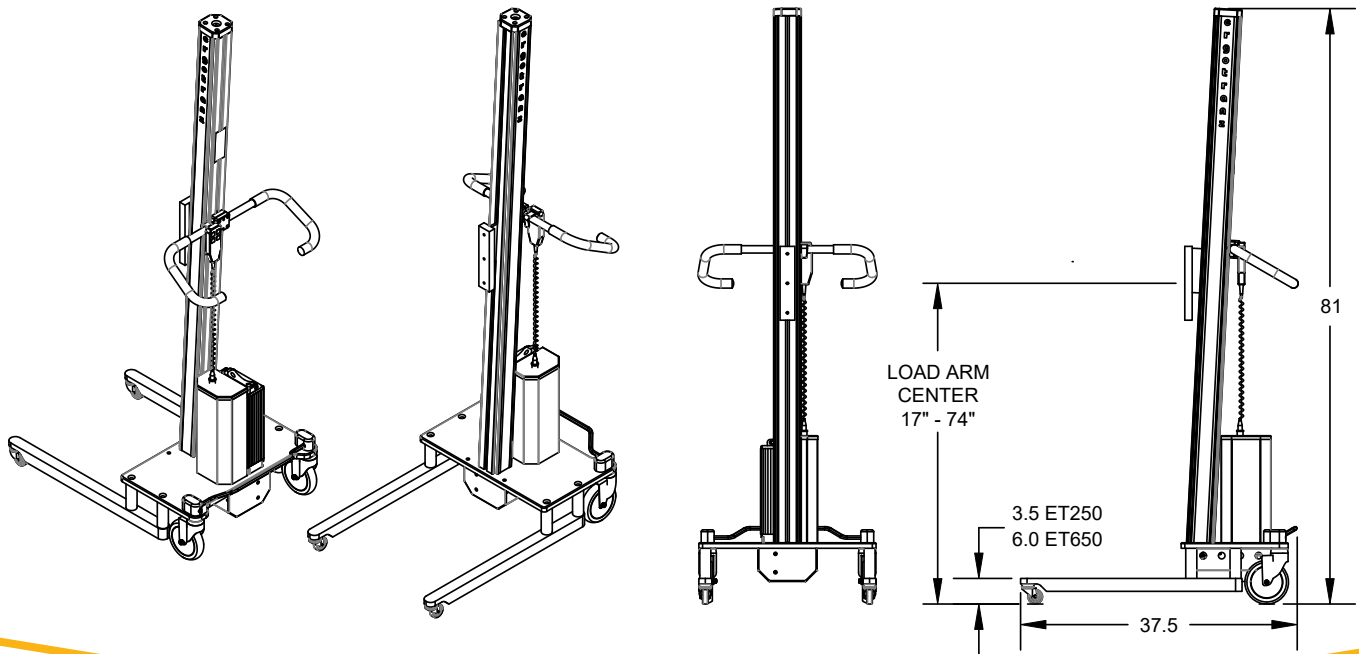
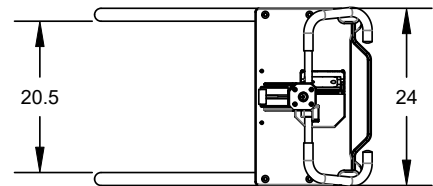

Call us today at 877-SEE-ERGO (877-733-3746) • sales@ergotronix.com • www.ergotronix.com

Rev D, 101, 3/2022  
© All rights reserved  
Ergotronix, Inc. 2022